

CTA Technical Information

CTA SERIES

Specification		CTA 250	CTA 500
Airflow	Industry standard (CFM)	6,000	8,500
Cooling Capacity*	.3 IWG (BTU/hr)	27,300	44,020
Power Consumption (total)	Power Max (W)	620	1,330
	Current - Rated (A)	7.0	14
Power Supply	Voltage / Phases / Hz	115 / 1 / 60	115 / 1 / 60
Controller	Type	Not Supplied	Not Supplied
Fan	Type	Axial	Axial
	Diameter (inches)	21.1	2.1
Motor	Type	PSC - 2 Speed	PSC - 2 Speed
	Shaft Speed Max (RPM)	1,150	1,650
	Output Max (W)	330	950
Pump	Type	Centrifugal	Centrifugal
	Motor	Synchronous	Synchronous
	Power - Rated (W)	0.7	0.7
	Flow rate (gal / min)	5.5	5.5
	Voltage / Phases / Hz	115 / 1 / 60	115 / 1 / 60
	Overload	Thermal One Shot Fuse	Thermal One Shot Fuse
Cooling pad Chillcel™	Enclosure Rating	IPX4	IPX4
	Size (inches)	33 1/2 x 14 3/4 H x 3 1/2 (4 Pads)	33 1/2 x 20 3/4 H x 3 1/2 (4 Pads)
Water	Pad area (feet²)	13.8	19.2
	Tank capacity (gal)	6.1	6.1
Shipping	Inlet (inches)	1/2" male BSP	1/2" male BSP
	Dimensions (inches) including pallet	45 1/4 x 45 1/4 x 29 1/2 H	45 1/4 x 45 1/4 x 3 1/2 H
Connecting Duct	Volume (feet³)	35	42.4
	Mass - Shipping (lbs)	141	148
	Mass - Operating (lbs)	192	198
	Length x Width (inches)	21 7/8 x 21 7/8 OR 17 3/4 x 17 3/4 Adapter	21 7/8 x 21 7/8 OR 19 3/4 x 19 3/4 Adapter

*Cooling capacity is measured to Australian Standard AS2913-2000, ambient of 100.4°F dry bulb & 69.8°F wet bulb, with room exit temperature of 81.3°F. Convair's CTA Series has been tested by the Nationally Recognized Testing Laboratory. ETL List to Standard for Electric Fans (UL-507).

Cooler Discharge Air Temperature Chart

Ambient Dry Bulb Temperature °F	Ambient Relative Humidity %								
	10	20	30	40	50	60	70	80	90
50	37	38	40	42	43	45	46	47	49
60	43	46	47	50	52	53	55	57	58
70	50	53	55	58	60	62	64	66	68
80	56	60	63	66	68	71	73	76	78
90	62	66	70	74	77	80	83	85	88
100	68	73	78	82	85	89	92	95	N/A
110	74	80	85	90	94	N/A	N/A	N/A	N/A
120	80	87	93	98	103	N/A	N/A	N/A	N/A
130	86	94	101	106	N/A	N/A	N/A	N/A	N/A

This chart represents approximate air temperatures based on 87% saturation efficiency at sea level from tests carried out to Australian Standard 2913.

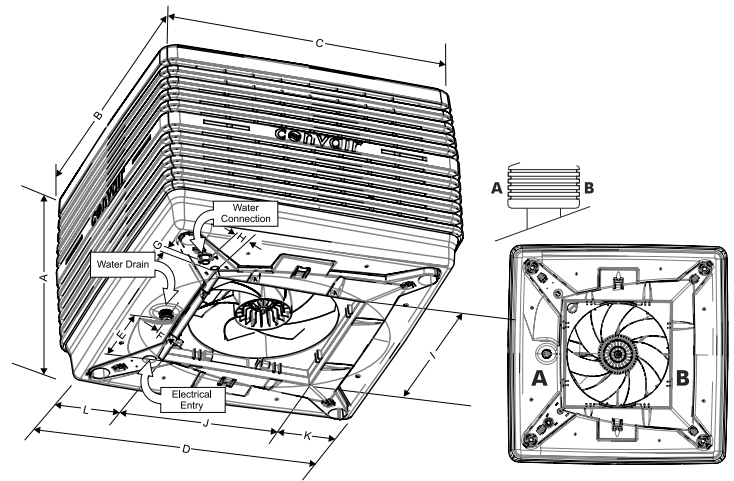

CABINET DETAILS

Model#	A	B	C	D	E	F	G	H	I	J	K	L
CTA 250	27	45 1/4	45 1/4	42 1/2	10 3/4	3 3/4	3 1/4	3 1/4	21 7/8	21 7/8	9 3/4	11
CTA 500	32 7/8	45 1/4	45 1/4	42 1/2	10 3/4	3 3/4	3 1/4	3 1/4	21 7/8	21 7/8	9 3/4	11

Note: All dimensions are in inches.

Typical installation

Drain outlet	1 1/2" BSP to 3/4" OD Reducer piece designed for push-on use with a flexible hose (3/4" ID) or solid PVC pipe (3/4" ID)
Water inlet	1/2" BSP to 3/8" Nom or 1/2" BSP to 1/4" compression adapter pieces
Electrical	1/2" Flexible conduit

FAN CURVE (CFM)

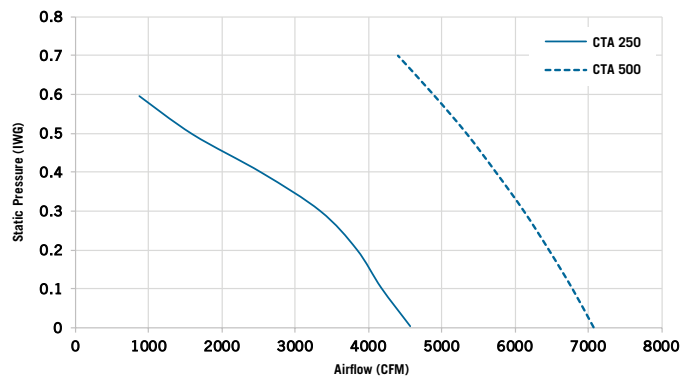

Model	Industry Standard CFM	Motor (HP)	Air Flow - Cubic feet/min (CFM) vs. Inch water gauge (IWG) HIGH SPEED						
			0.0	0.1	0.2	0.3	0.4	0.5	0.6
CTA 250	6,000	1/2	4,560	4,170	3,840	3,350	2,560	1,630	910
CTA 500	8,500	1 1/4	7,070	6,780	6,460	6,120	5,740	5,340	4,890

www.seeleyinternational.com



Seeley International Americas
 1002 S. 56th Avenue, Suite #101, Phoenix, AZ 85043 | 602.353.8066
 4430 Glencoe Street, Denver, CO 80216 | 303.375.0878
ussales@seeleyinternational.com

